



EVOMAQ[®]
EQUIPMENTS

CONCRETE BT PUMP

**THE BASIS OF YOUR
CONSTRUCTION SITE
NEEDS TO BE RELIABLE**



** Image for illustration purposes only*

With evolution even in the name, the BT PUMP is another proof of the continuous search for improvements. Equipment developed with the main purpose of reducing the operational cost of EVOMAQ customers, since it eliminates the need to use at least one truck and all of its aggregate costs.

ATTENTION TO WHAT REALLY MATTERS, YOUR PROFIT



COOLER

An efficient cooling system stabilizes the oil temperature, always keeping it viscous and preventing premature wear of the hydraulic system.

CARGO TRANSFER

The BT Pumps of Evomaq have an exclusive load transfer system, which makes your day-to-day work on construction sites even easier and faster, allowing you to transfer from one concrete mixer to another in up to 12 minutes.



CONTROL PANEL

The EVOMAQ® pump's electrical system stands out for the simplicity of its design, facilitating the operation and eliminating relays and timers, by using a limit switch. As a result, a reduction in maintenance costs is achieved again.



POWER TAKE-OFF

Similar to equipment for civil construction, such as concrete mixers and boom pumps, EVOMAQ equipment was designed to take advantage of the truck's engine, offering reliability and durability without compromising its efficiency even in extreme situations, allowing a reduction in the final cost of the investment.

PIPE SUPPORT

The exclusive support system for the piping is intended to organize and facilitate safe transportations of the piping.



HYDRAULIC RESERVOIR

An efficient air filtration system, complete with a return system and thermometer, minimizes the likelihood of issues with the hydraulic system. This not only significantly extends the lifespan of the equipment but also reduces overall maintenance costs.



PUMPING SYSTEM

The improvement of the pumping system allows a significant reduction in the number of components, boosting productivity and avoiding possible maintenance costs.

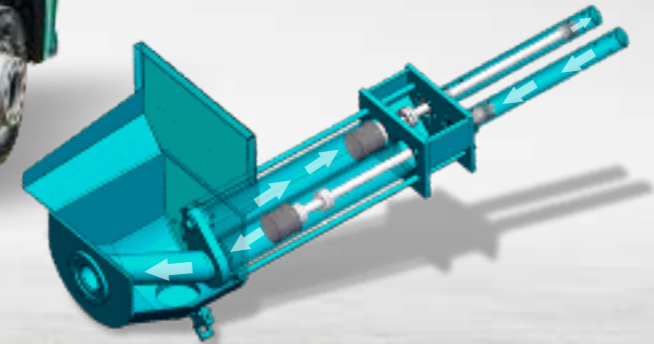

HOPPER

The rounded hopper design facilitates cleaning, in addition to directing concrete more easily to the transport liners, increasing pumping efficiency. The hopper cleaning valve is also noteworthy, with an exclusive lever system that allows it to be opened from the side of the equipment, making cleaning and conservation even easier.

HYDRAULIC MIXER

Our equipment features a robust hydraulic mixer, ensuring consistent mortar flow between successive loads of concrete.



TECHNICAL SPECIFICATIONS

MODELS	1527	1560
Theoretical maximum efficiency (m ³ /h)	27	51
Cycles per minute	35	24
Cylinder diameter (mm)	80/45	90/63
Maximum aggregate size (mm)	25	25
Cylinder stroke (mm)	710	1000
Transport liners diameter	150	180
Concrete volume per stroke (liters)	12,54	35,62
Bypass tube type	"S"	"S"
Horizontal pumping distance	150	350
Vertical pumping distance	45	100
Weight with PTO	800	850

* The volume, horizontal distance and vertical distance cannot be achieved simultaneously. To achieve the maximum capacities contained in this catalogue, the transport piping, concrete mix, minimum slump, aggregate size and pumping conditions must be taken into account.



WE SERVE THE ENTIRE
COUNTRY

Tel.: +55 19 3806.1478 | +55 19 97158.9961
vendas@evomaq.com.br
www.evomaq.com.br



EXPLORE OTHER SOLUTIONS WITHIN THE EVOMAQ® EQUIPMENT LINEUP



SMALL-SIZED CONTINUOUS FLIGHT AUGER (CFA)



BORED PILE DRILLS EVOMAQ®