



evomaq[®]
EQUIPMENTS

CATALOG
BORED PILE DRILL
ON TRUCK
P100/15 | P140/20



EVOMAQ BORED PILE DRILL ON TRUCK

DRIVEN BY EVOLUTION

Designed for diameters up to 1.40 meters and depths of up to 20 meters, the truck-mounted bored pile drill is ideal for projects where there is no water table presence.

The EVOMAQ® truck-mounted bored pile drill P100/15 and P140/20 have a compact turret low height that allows the use of equipment inside warehouses and buildings with restricted ceiling heights.

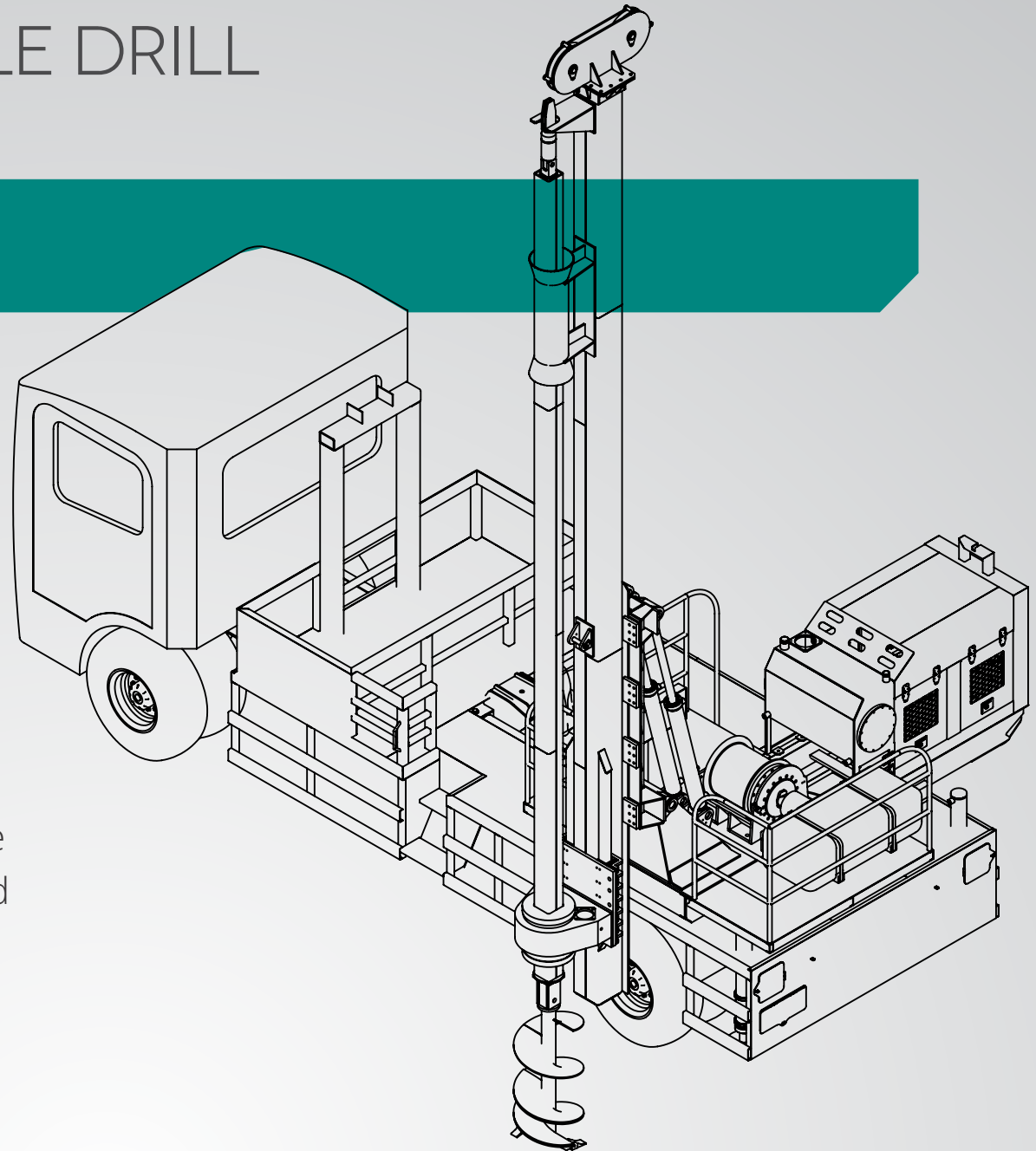

SPECIAL FEATURES

- POWERFUL MWM ENGINE
- TURRET WITH LOW HEIGHT
- HIGH TORQUE
- EASY TRANSPORTATION



TECHNICAL SPECIFICATIONS

	P100/15	P140/20
Overall equipment width	2530mm	2530mm
Total length of the equipment	8450mm	8450mm
Total length of the equipment for work	9300mm	9300mm
Minimum drilling diameter	250mm	250mm
Maximum drilling diameter	1000mm	1400mm
Maximum drilling depth	15m	20m
Maximum head rotation	57 RPM	50 RPM
Maximum torque	1.500 kgf.m	3.000 kgf.m
Extraction force	6.000 kgf.m	6.000 kgf.m
Engine and power	MWM 229-4NA 83cv	MWM 4.12 TCA 152cv
Total equipment weight	10.230 kg	10.230 kg
Total weight of the set (equipment/truck)	15.000 kg	15.560 kg

DIMENSIONS: OPERATIONAL WORK

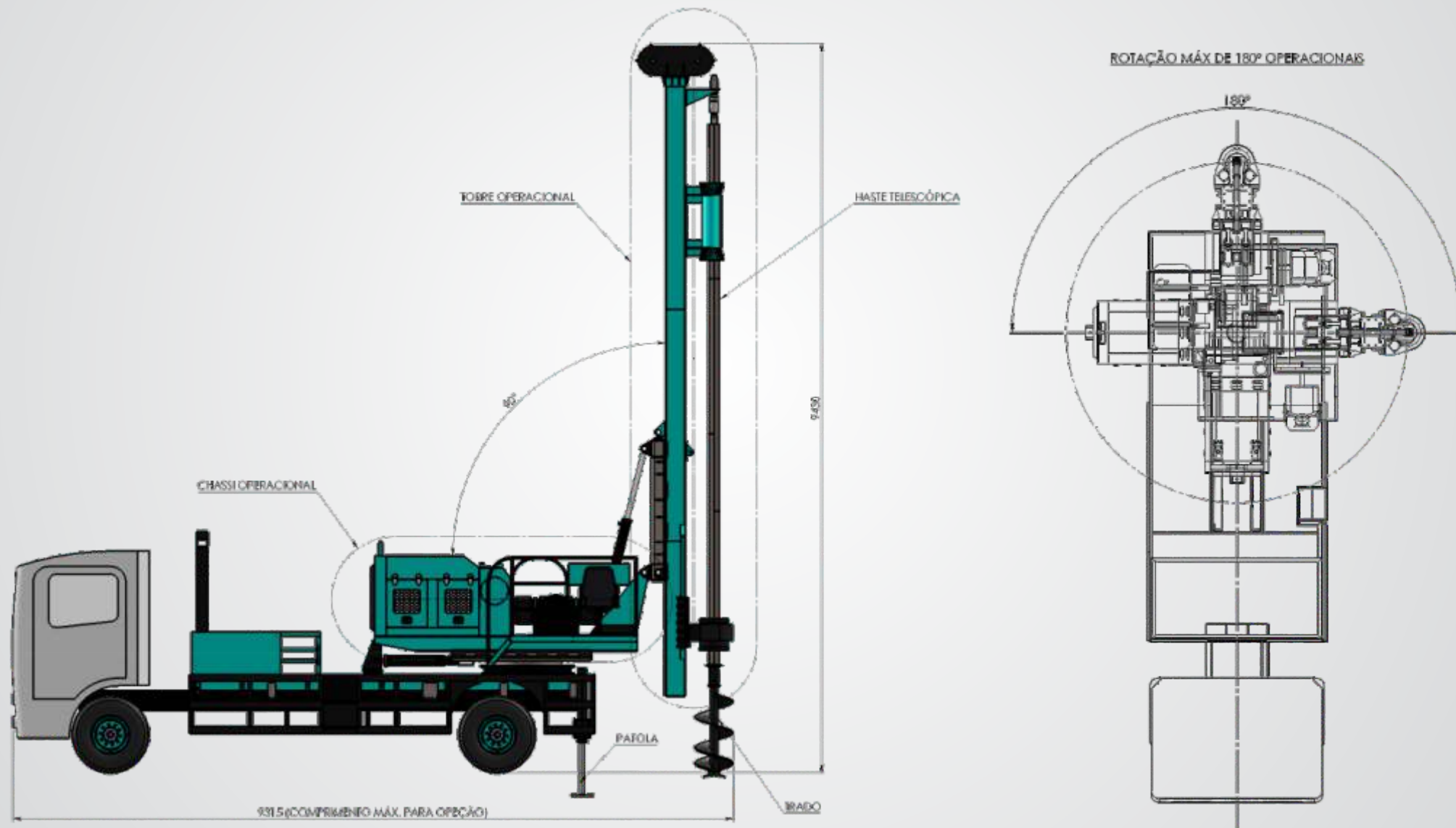

DIMENSIONS: TRANSPORT

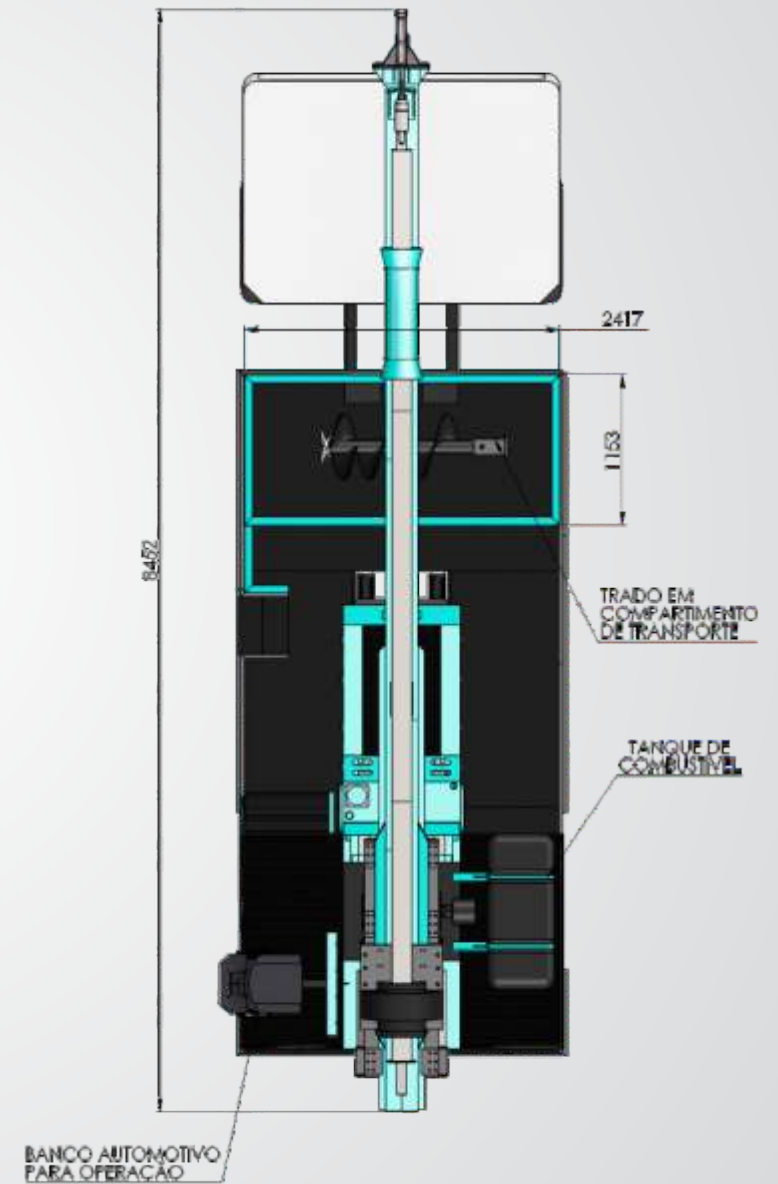
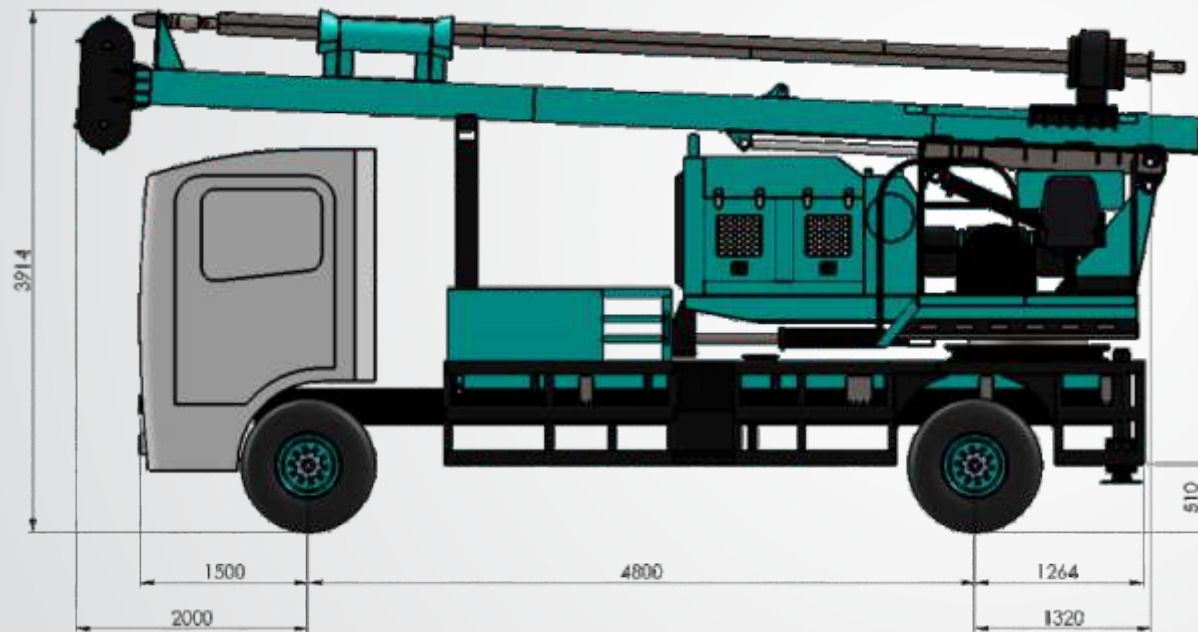



EVOMAQ[®]
EQUIPMENTS

MOGI MIRIM/SP
TEL.: (+55) 19 3806.1478 | 19 97158.9961
E-MAIL: VENDAS@EVOMAQ.COM.BR

WWW.EVOMAQ.COM.BR



EXPLORE OUR LINE OF CONCRETE PUMPS FOR ADDITIONAL INSIGHTS



**CONCRETE
AUTO PUMP
EVOMAQ[®]**



**BETON
CONCRETE PUMP
EVOMAQ[®]**



**CRAWLER
PUMP
EVOMAQ[®]**



**STATIONARY
CONCRETE PUMP
EVOMAQ[®]**