



evomaq[®]
EQUIPAMENTOS

CATALOG

E80/20

CONTINUOUS FLIGHT AUGER
DRILL UNDER EXCAVATOR CHASSIS



**CONSTANT
EVOLUTION**

CONTINUOUS FLIGHT AUGER DRILL (CFA DRILL)

EVOMAQ®

E80/20

SPECIAL FEATURES

- HIGH TORQUE OF 10.000 Kgf.m
- CABIN WITH MORE COMFORT AND TECHNOLOGY
- STRONG, COMPACT DRILLING HEAD WITH HYDRAULIC MOTORS AND REDUCERS
- DIAMETER UP TO 800 mm
- 360° ROTATION
- EXCLUSIVE HYDRAULIC VISE FOR ALL DIAMETERS



COMPONENTS

- CONTROL PANEL
- MONITORING COMPUTER
- HYDRAULIC TOWER ADJUSTMENTS
- CONVEYORS
- TURRET FOOT



SPECIAL FEATURES

WWW.EVOMAQ.COM.BR



HIGH TORQUE OF 10.000 KGF.M

In this equipment model, we adapted a large machine into a small one! The EVOMAQ E80/20 has a high torque compared to a large machine. This characteristic provides a significant advantage, enhancing both daily production rates and the equipment's durability when encountering tough, resistant soil layers.



CABIN WITH MORE COMFORT AND TECHNOLOGY

Experience the full spectrum of comfort and cutting-edge technology that the excavator chassis has to offer. In this version, you'll also notice a slight expansion of interior space. Take a closer look!

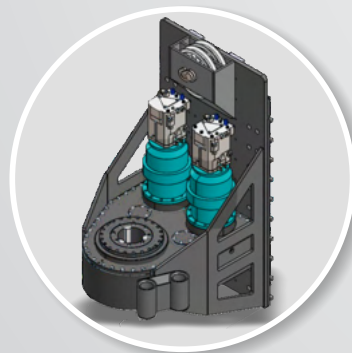

STRONG, COMPACT DRILLING HEAD WITH HYDRAULIC MOTORS AND REDUCERS

Designed to operate with two hydraulic motors and featuring an innovative dual reducer design, this head delivers an impressive maximum torque of 10,000 kgf.m, maintaining its compact characteristic. This not only minimizes component wear, but also substantially increases production for our customers.

SPECIAL FEATURES

WWW.EVOMAQ.COM.BR



DIAMETER UP TO 700 MM

As previously mentioned, the EVOMAQ E80/20 is a large machine with the characteristics of a small one and proves this not only in relation to its high torque but also in its capacity for drilling up to 800 mm in diameter, providing much more autonomy for the execution of your projects.



360° ROTATION

EVOMAQ has used techniques and features to provide a 360° ROTATION around the equipment to maximize use, productivity and safety.

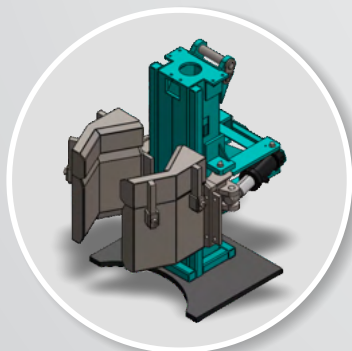

EXCLUSIVE HYDRAULIC VISE FOR ALL DIAMETERS

To keep the auger alignment during the drilling, the drill of EVOMAQ® has an exclusive hydraulic vise system for all diameters, facilitating and ensuring enhanced safety for individuals involved in the operation.

COMPONENTES

WWW.EVOMAQ.COM.BR



CONTROL PANEL

With an easy-to-operate, intuitive and strategically located instrument panel, the operator has complete control over the equipment.



MONITORING COMPUTER

The EVOMAQ® Continuous Flight Auger Drill (CFA) has a high-tech monitoring computer that generates accurate, real-time data on drilling and concreting, through detailed graphics, providing reliability for the customer.

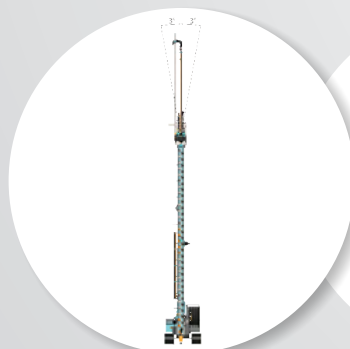

TOWER SIDE SLOPE



TOWER ELEVATION

HYDRAULIC TOWER ADJUSTMENTS

In addition to greater agility, the hydraulic adjustments of the tower are essential for the safe displacement of the EVOMAQ drill rig on construction site.

When in movement, the tower can be tilted sideways and backwards, maintaining the center of gravity and providing even more safety for the operation.

COMPONENTS

WWW.EVOMAQ.COM.BR

CONVEYORS



At EVOMAQ, meticulous planning allows us to select the ideal chassis or tracks model that seamlessly adapts to various soil types, enhancing maneuverability and overall performance.

TURRET FOOT



In order to provide greater stability and safety when executing the pile, the turret foot has large dimensions, ensuring higher machine stability and precision when the auger is removed.

TECHNICAL SPECIFICATIONS

Minimum drilling diameter	300 mm
Maximum drilling diameter	800 mm
Maximum drilling depth	20m (14 + 6)
First gear rotation	09 RPM
Second gear rotation	14 RPM
Third gear rotation	20 RPM
Fourth gear rotation	29 RPM
Maximum torque	13.000 kgf.m
Extraction force	45.000 kfg
Overall equipment width (transport)	2690mm*
Overall equipment width (operational)	2690mm*
Total track shoe width	700mm
Track length	4240mm*
Total equipment weight (transport)	22 Ton*
Engine	100cv*
Total Height (Work)	23192mm*
Total Height (Transport)	2990mm*
Total Length (Work)	5875mm*
Total Length (Transport)	9377mm*

Excavators for adaptation



* Technical specifications, dimensions and weight of the equipment, depending on the model chosen.

* For other chassis manufacturers, project development will be required.

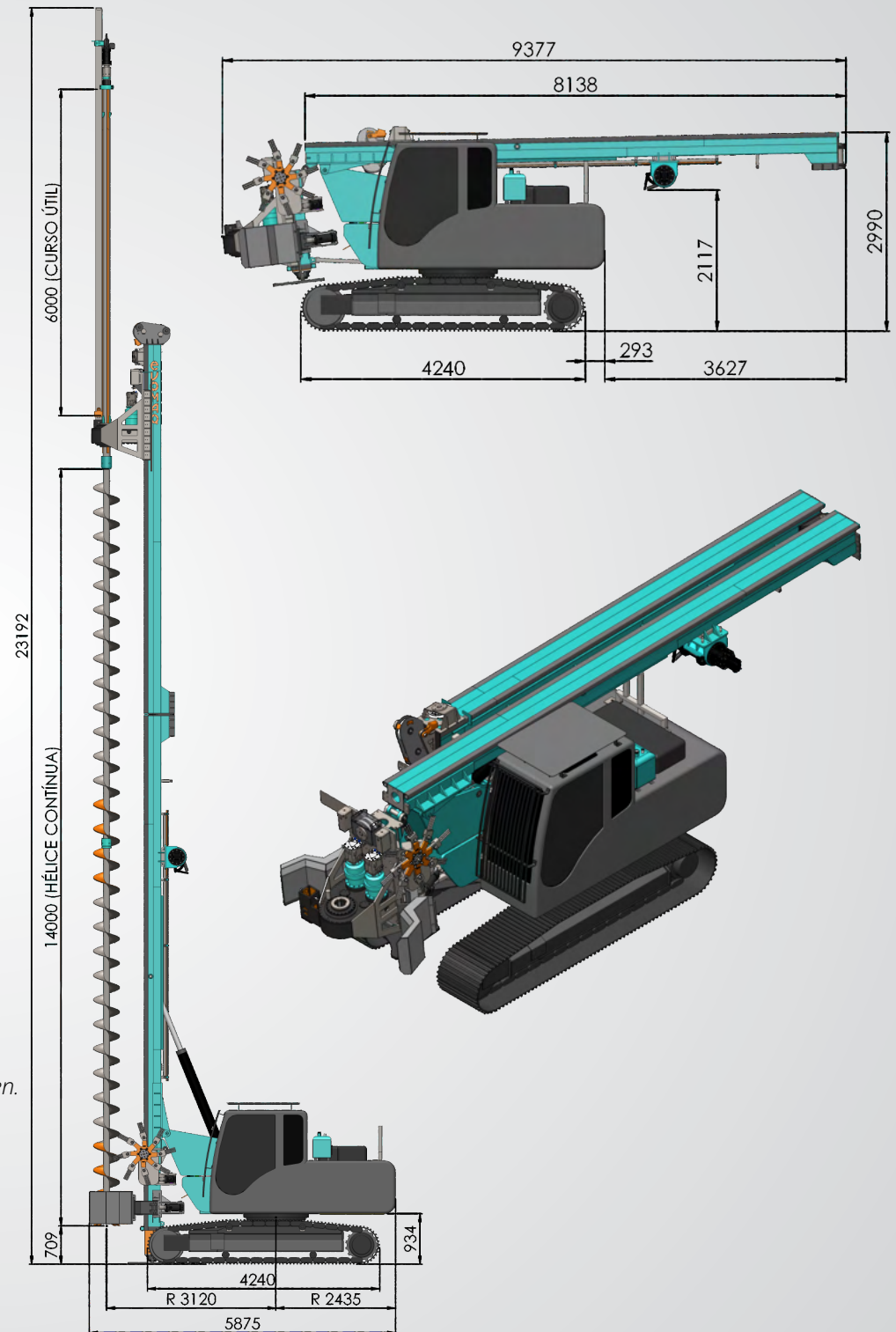



EVOMAQ[®]
EQUIPAMENTOS

MOGI MIRIM/SP
TEL.: (+55) 19 3806.1478 | 19 97158.9961
E-MAIL: VENDAS@EVOMAQ.COM.BR

WWW.EVOMAQ.COM.BR



EXPLORE OUR LINE OF CONCRETE PUMPS FOR ADDITIONAL INSIGHTS



CONCRETE
AUTO PUMP
EVOMAQ[®]



BT
CONCRETE PUMP
EVOMAQ[®]



CRAWLER
PUMP
EVOMAQ[®]



STATIONARY
CONCRETE PUMP
EVOMAQ[®]